

ULTRA-SLIM® Thin-Section Bearings

Ideal for applications in robotics, inspection equipment, satellites, cameras... anywhere precise positioning and lightweight designs are critical.

At just 2.5 mm wide, ULTRA-SLIM® bearings are available in bore sizes ranging from 35 mm to 170 mm for an array of applications. Their compact profile allows you to use ULTRA-SLIM® bearings in many highly confined spaces.

Precision-engineered ULTRA-SLIM® bearings are made of stainless steel for corrosion resistance. They are available in angular contact (Type A), radial contact (Type C), and four-point contact (Type X) styles. (See selection charts at right.)

Hybrid bearings with ceramic balls are available upon request. These configurations are used often when lubrication is marginal or when lower wear generation and/or lower torque levels are required.

Figure 2-11

How to identify ULTRA-SLIM® Bearings using our part number code

Position	1	2	3	4	5	6	7	8	9	10
Nomenclature	Material	Bore (mm)			Width(mm)		Type	Separator	Precision	Internal Fit
Example	S	1	1	0	0	3	C	S	0	K

Explanation of position numbers:

Position 1—Material

S = AISI 440C races and balls
(Standard for Series)

Positions 2, 3 and 4—Bore

Nominal bearing bore in mm.

Positions 5 and 6—Width

Nominal radial race width in mm.

Position 7—Bearing Type

A = Angular Contact
C = Radial Contact
X = Four-Point Contact

Position 8—Separator

S = Spacer balls
F = Full complement of load balls

Position 9—Precision

0 = KAYDON standard precision class

Position 10—Internal Fit

A = 0.000 - 0.013 mm clearance
C = 0.013 - 0.025 mm clearance
E = 0.025 - 0.051 mm clearance
K = 0.000 - 0.013 mm preload
M = 0.013 - 0.025 mm preload
empty = standard internal fitup if not specified

Performance and Application Considerations

ULTRA-SLIM® bearings are unique in that their extremely thin cross section enables them to provide great size and weight reductions for light to medium duty applications with slow or intermittent rotation.

Given the fact that these bearings will most likely be used in lightly loaded applications where saving weight and space are the main objective, the loading values shown assume that the shaft and housing will also be of light construction. This will allow for greater bearing ring movement under load than traditional heavy section bearings. Thus the *loading limits* for capacity are not based on ABMA standards.

Depending on the support provided by the shaft and housing, this movement can create increased stress levels within the bearing. Distortion of the shaft and housing under load will transfer to the bearing, causing increased stress levels which could lead to premature failure and/or erratic torque conditions.

The impact of non-uniform shaft and housing distortions is best found by testing. If problems are experienced, increased rigidity of the shaft and housing may be necessary. If the shaft and housing are of sufficient rigidity, it may be possible for the bearings to support greater loads than the loading limits provided.

ULTRA-SLIM® Bearing Selection Data

Angular Contact Type A									
KAYDON Bearing Number	Dimensions in mm				Capacity		Loading Limits		Mass in Grams
	Bore	Outside Diameter	Land Dia. L ₁	Land Dia. L ₂	Radial Newtons		Thrust Newtons ^③		
					Static ^①	Dyn. ^②			
*S03503AS0	35	41	37.2	38.8	382	383	1334	5	
*S06003AS0	60	66	62.2	63.8	649	552	1112	9	
*S07003AS0	70	76	72.2	73.8	756	609	1068	11	
*S07403AS0	74	80	76.2	77.8	799	632	1045	11	
*S08003AS0	80	86	82.2	83.8	863	663	1001	12	
*S09003AS0	90	96	92.2	93.8	970	716	956	13	
*S10003AS0	100	106	102.2	103.8	1077	765	890	15	
*S11003AS0	110	116	112.2	113.8	1183	814	867	16	
*S12003AS0	120	126	122.2	123.8	1290	863	823	18	
*S13003AS0	130	136	132.2	133.8	1407	912	778	19	
*S14003AS0	140	146	142.2	143.8	1514	956	734	21	
*S15003AS0	150	156	152.2	153.8	1621	1001	712	22	
*S16003AS0	160	166	162.2	163.8	1727	1045	689	24	
*S17003AS0	170	176	172.2	173.8	1834	1085	667	25	

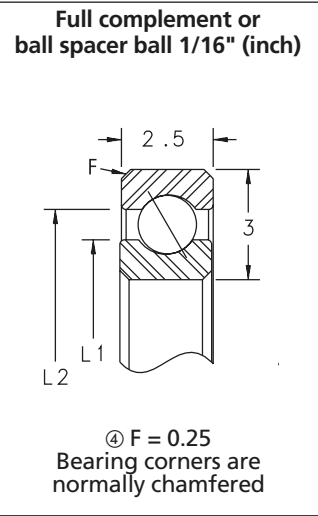

Radial Contact Type C								
KAYDON Bearing Number	Dimensions in mm				Capacity		Mass in Grams	
	Bore	Outside Diameter	Land Dia. L ₁	Land Dia. L ₂	Radial Newtons			
					Static ^①	Dyn. ^②		
*S03503CS0	35	41	37.2	38.8	418	418	5	
*S06003CS0	60	66	62.2	63.8	711	605	9	
*S07003CS0	70	76	72.2	73.8	827	667	11	
*S07403CS0	74	80	76.2	77.8	875	689	11	
*S08003CS0	80	86	82.2	83.8	944	725	12	
*S09003CS0	90	96	92.2	93.8	1062	783	13	
*S10003CS0	100	106	102.2	103.8	1178	841	15	
*S11003CS0	110	116	112.2	113.8	1295	894	16	
*S12003CS0	120	126	122.2	123.8	1412	943	18	
*S13003CS0	130	136	132.2	133.8	1540	1001	19	
*S14003CS0	140	146	142.2	143.8	1658	1050	21	
*S15003CS0	150	156	152.2	153.8	1774	1099	22	
*S16003CS0	160	166	162.2	163.8	1891	1143	24	
*S17003CS0	170	176	172.2	173.8	2006	1192	25	

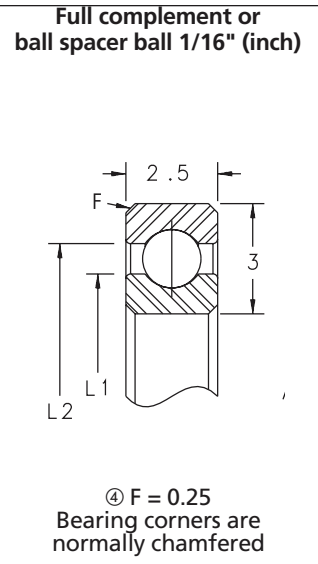

4-Point Contact Type X									
KAYDON Bearing Number	Dimensions in mm				Capacity		Loading Limits		Mass in Grams
	Bore	Outside Diameter	Land Dia. L ₁	Land Dia. L ₂	Radial Newtons		Thrust Newtons ^③	Moment N-m ^③	
					Static ^①	Dyn. ^②			
*S03503XS0	35	41	37.2	38.8	711	585	1045	7.9	5
*S06003XS0	60	66	62.2	63.8	1208	847	934	11.8	9
*S07003XS0	70	76	72.2	73.8	1407	934	890	13.0	11
*S07403XS0	74	80	76.2	77.8	1487	965	867	13.4	11
*S08003XS0	80	86	82.2	83.8	1606	1015	845	14.0	12
*S09003XS0	90	96	92.2	93.8	1805	1096	801	14.9	13
*S10003XS0	100	106	102.2	103.8	2003	1177	756	15.6	15
*S11003XS0	110	116	112.2	113.8	2201	1252	734	16.6	16
*S12003XS0	120	126	122.2	123.8	2400	1320	689	17.0	18
*S13003XS0	130	136	132.2	133.8	2618	1401	645	17.2	19
*S14003XS0	140	146	142.2	143.8	2818	1470	623	17.8	21
*S15003XS0	150	156	152.2	153.8	3016	1538	601	18.4	22
*S16003XS0	160	166	162.2	163.8	3215	1600	578	18.9	24
*S17003XS0	170	176	172.2	173.8	3413	1669	556	19.2	25

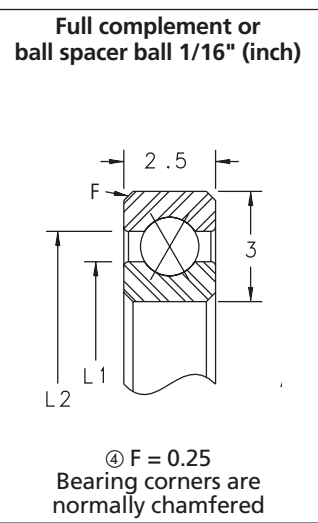

① Static radial capacities are based on maximum allowable contact stresses. Adequate support of the races is assumed to help assure uniform ball support.
 ② Dynamic radial capacities are included for life calculation purposes. These are based on the assumption that the shaft and housing have adequate strength to support the loads without causing excessive distortion of the bearing rings.
 ③ Higher loading limits may be achieved with sufficiently rigid supports that will better restrict the movement of the bearing races under load.
 ④ Corner size is the maximum shaft or housing fillet radius that the bearing corners will clear.
 *Contact KAYDON for lead time and minimum purchase requirement.